

# EVOCHARGE 50A EV CHARGING STATIONS

QUICK INSTALLATION GUIDE  
EVSE 50 | HOME 50



ATTENTION: Read and follow all instructions, warnings, dangers, and notifications before installing. Return this guide to the owner after installation.

## IMPORTANT SAFETY INFORMATION

Read and follow all instructions, warnings, dangers, and notifications before installing and using EvoCharge EVSE Products. **THIS CHARGING STATION MUST BE INSTALLED BY A LICENSED ELECTRICIAN.** Failure to follow these guidelines may result in death, injury, or property damage and will void the product warranty. Save these instructions.



### WARNING

- High Voltage present, disconnect all power before servicing or installing the product. Failure to follow these guidelines may result in death, personal injury, or damage to property.
- Do not install or use the EVSE near flammable, explosive, harsh, or combustible materials, chemicals, or vapors. Failure to follow these guidelines can result in death, personal injury, or damage to property.
- Improper amperage setting to the supply wire sizing that does not meet NFPA 70 NEC 625 specifications, temperature rating and breaker sizing may result in death, personal injury, or damage to property.
- Installation must be done following an approved EvoCharge installation practice. Failure to follow these guidelines can result in death, personal injury, or damage to property.
- Do not use the EVSE if the flexible power cord or cable is frayed, broken, damaged, or fails to operate. Failure to follow these guidelines can result in death, personal injury, or damage to property.
- Operating temperature range is -30°C to +50°C (-22°F to +122°F); operating this device outside of this operating range may result in death, personal injury, or damage to property.

**CAUTION**

- Copper wire must be used and sized to follow NFPA 70 NEC wiring code guidelines.
- Children should not operate and must be supervised when around the equipment.
- Do not touch EVSE Connector's end terminals with fingers or sharp metallic objects, such as wire, tools, or needles. Damage to the terminals can result in damage to property.
- This product can expose you to one or more chemicals that are known to the state of California to cause cancer. Please see product packaging for Proposition 65 warning.
- The EVSE should not be used if there is any visible damage to the enclosure.

**NOTICE**

- This equipment must be grounded through a dedicated permanent wiring system or an equipment-grounding conductor according to the NFPA 70 NEC 626 specifications. Failure to properly ground this equipment could result in damage to property, serious injury, or death.
- Handle the equipment with care during transportation. To prevent damage to the equipment and its components, do not subject it to strong force or impact and do not pull, twist, tangle, drag or step on the equipment.
- Incorrect installation and testing of the equipment could potentially damage the vehicle's battery, components, and/or the equipment itself.
- In areas that experience frequent thunderstorms with lightning or areas that experience frequent power outages and power supply issues, add surge protection at the service panel for all circuits. Ensure all ground and power connections follow NFPA 70 NEC guidelines.
- Installation must be done by a licensed electrician.

## Prepare the Charger

- Remove T10 fasteners located on the bottom of the front cover.
- Pull firmly up on the bottom of the front cover and disengage tabs located mid-panel.
- Remove the six T25 fasteners holding down the sealed enclosure cover.

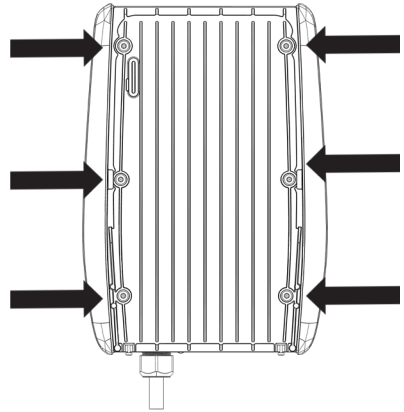
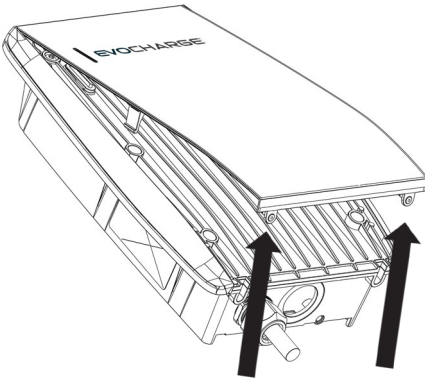
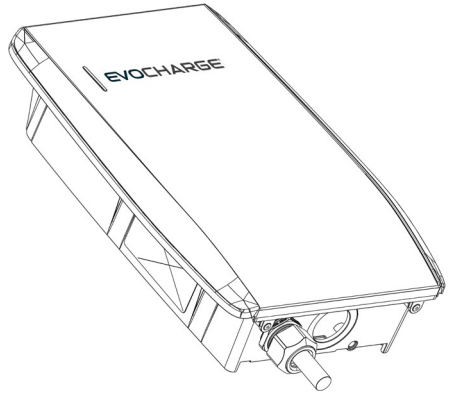

## Installation of Mounting Bracket and Cable Holster

Charger and holster must be mounted to a solid surface, directly to wood stud or concrete/brick wall. Use the included mounting screws when mounting to a wood stud wall.

Screw suggestion:

- For masonry walls, use  $\frac{1}{4}$ " x 2" concrete screws.

When installing the Mounting Bracket ensure there is 6" minimum clearance above the bracket to allow for charger placement and that it is located close enough that the electrical wires can reach the terminal block located within the unit.

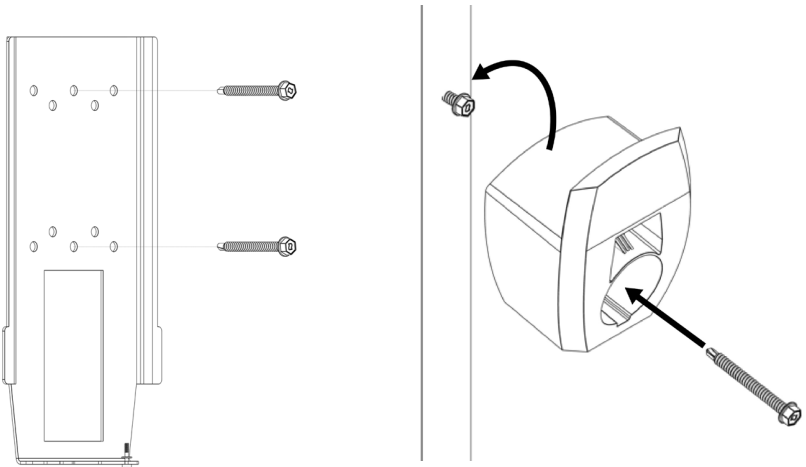

## Mount Charger to Bracket

- Slide the charger onto the mounting bracket.
- Fix the charger on the mounting bracket with T10 screw and screw washer.

## Wiring the Charger



**WARNING:** Failure to disconnect power prior to installation can lead to serious injury or death.

**CAUTION:** To reduce the risk of fire, connect only to a circuit that has the correct overcurrent protection in accordance with the National Electrical Code, ANSI/NFPA 70, and the Canadian Electrical Code, Part I, C22.1.

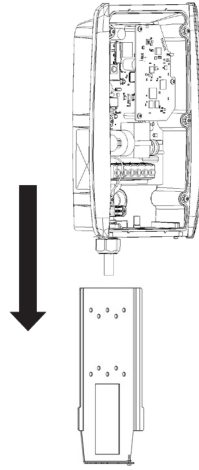

Install torque 3-4 lb-in  
(0.3-0.5 N-m)

## Setting the Amperage of the Charger

- Verify the power to the unit is off.
- Adjust the amperage output dial as needed.
- Using the table below, find the switch setting that corresponds to the desired charger rating (maximum amperage).
- Using a screwdriver, rotate the arrow on the rotary switch to the desired amperage level for the installation.
- Apply corresponding amperage sticker from supplied decal sheet to charger and service panel.

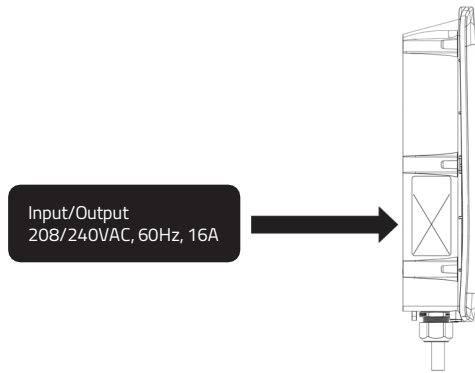
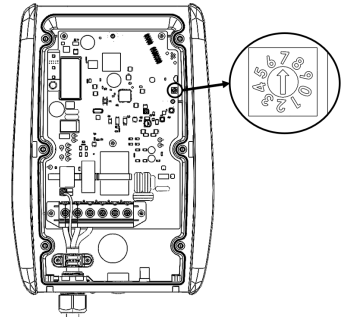

Table 1

| Switch Position | Charger Rating            | Breaker Rating | Minimum Conductor Size (75° C) AWG (L1/L2) | Minimum Equipment Grounding Conductor AWG (G) |
|-----------------|---------------------------|----------------|--------------------------------------------|-----------------------------------------------|
| 3               | 16A                       | 20A            | 12                                         | 12                                            |
| 4               | 24A                       | 30A            | 10                                         | 10                                            |
| 5               | 32A                       | 40A            | 8                                          | 10                                            |
| 6               | 40A                       | 50A            | 8                                          | 10                                            |
| 7               | 48A                       | 60A            | 6                                          | 10                                            |
| 8               | 50A                       | 70A            | 4                                          | 8                                             |
| 0, 1, 2, 9      | Switch positions not used |                |                                            |                                               |

## Electrical Wiring to the Charger

**CAUTION:** Use copper conductors only. Fix wire on the corresponding terminal block position. The wiring instructions are printed in front of the terminal block (L2/G/L1).

- Table 1 provides a reference for the minimum conductor size for the circuit from the panel to the EVSE via raceway (NEC 310.16). The required conductor size will vary due to temperature and cable length.
- Table 1 provides a reference for minimum equipment ground conductor size based on NEC 210.122.

The charger may be wired using the conduit knock-outs located on the bottom or rear of the enclosure. Select the applicable conduit in accordance with local and national electric code standards to the EVSE to maintain NEMA 4 rating.

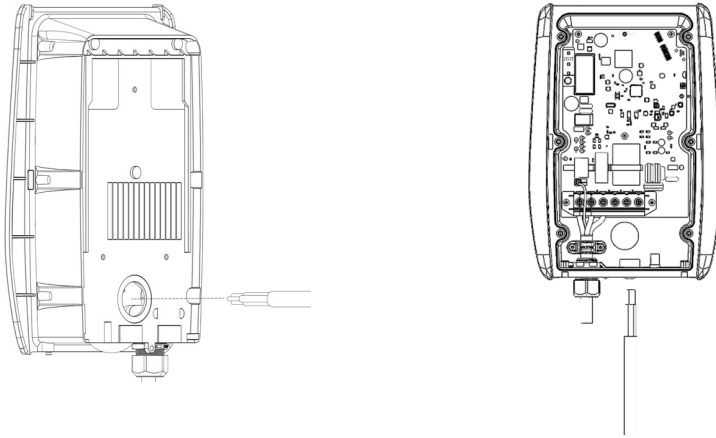

1. Strip wiring back 18mm as shown in the diagram.
2. Insert wires to the correct terminal location.
3. Torque the terminal screws according to the table below.

MAX: 19mm (.75")  
MIN: 18mm (.71")

| AWG   | Torque Pound Inches (N*m) |
|-------|---------------------------|
| 18-10 | 20 (2.3)                  |
| 8     | 20 (2.8)                  |
| 6-4   | 35 (4.0)                  |
| 3     | 35 (4.0)                  |
| 2     | 40 (4.5)                  |



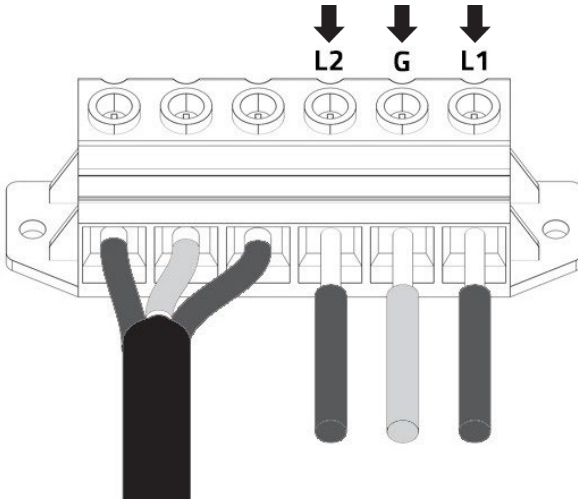

Terminal block wiring position

## Complete Installation

- Carefully re-install the sealed enclosure cover and front cover.
- Powering the charging station:
  - Turn the breaker on.
  - After start up sequence of approximately 3 minutes, LED indicator light will illuminate green (EVSE) or white (Home 50).
  - If it is not green, see full manual for troubleshooting.

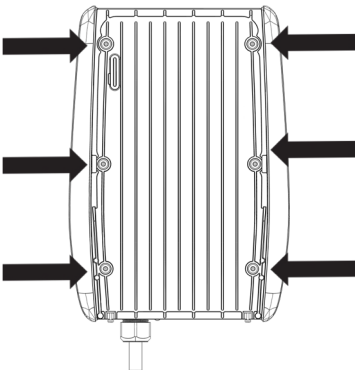

Re-sealing torque 18-24 lb-in  
(2.0-2.7 N-m)

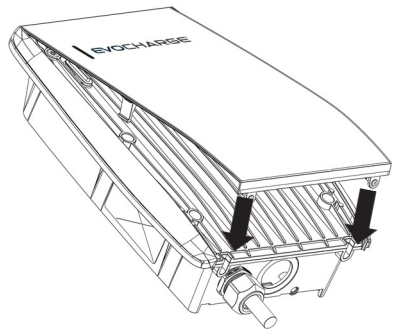

Install torque 3-4 lb-in  
(0.3-0.5 N-m)

| Specifications                      |                                                                                      |
|-------------------------------------|--------------------------------------------------------------------------------------|
| <b>AC Power Output Rating</b>       | Max 12 kW (240 VAC * 50A)                                                            |
| <b>AC Voltage Input Rating</b>      | 208 / 240 VAC 60Hz 1Ø                                                                |
| <b>Amperage Input Rating</b>        | 50A maximum (de-ratable)                                                             |
| <b>Power Wiring</b>                 | L1, L2, Earth Gnd (no neutral)                                                       |
| <b>Ground Fault Detection</b>       | 20 mA CCID                                                                           |
| <b>Open Safety Ground Detection</b> | Continuous monitoring of presence of earth ground                                    |
| <b>Weight</b>                       | 11.68lbs (5.3 kg)                                                                    |
| <b>Dimensions</b>                   | 9.7in (245mm) W x 13.8in (351mm) H x 3.5in (88mm) D                                  |
| <b>Ventilation</b>                  | Not required                                                                         |
| <b>Environmental Rating</b>         | NEMA 4                                                                               |
| <b>Operating Temperature</b>        | -22°F to 122°F (-30°C to 50°C)                                                       |
| <b>Storage Temperature</b>          | -40°F to 158°F (-40°C to 70°C)                                                       |
| <b>Operating Humidity</b>           | Up to 95% RH (non-condensing)                                                        |
| <b>EMI Compliance</b>               | FCC Part 15 Class B                                                                  |
| <b>Safety and Compliance</b>        | UL2594, UL2231-1, UL2231-2<br>NEC Article 625<br>ENERGY STAR® certified<br>– pending |
| <b>Communications</b>               | 2.4 GHz and 5 GHz (802.11 b/g/n/ac)<br>Bluetooth® wireless technology                |

ENERGY STAR and the ENERGY STAR mark are registered trademarks owned by the U.S. Environmental Protection Agency.

ENERGY STAR products are third-party certified by an EPA-recognized Certification Body.

The Bluetooth® word mark and logos are registered trademarks owned by Bluetooth SIG, Inc. and any use of such marks by EvoCharge, Inc. is under license. Other trademarks and trade names are those of their respective owners.

FCC ID: 2BEYO-HEVSE50

This device complies with part 15 of the FCC Rules. Operation is subject to the following two conditions:

1. This device may not cause harmful interference.
2. This device must accept any interference received, including interference that may cause undesired operation.

Changes or modifications not expressly approved by EVOCHARGE INC. could void the user's authority to operate the equipment.

Note: This equipment has been tested and found to comply with the limits for a Class B digital device, pursuant to part 15 of the FCC Rules. These limits are designed to provide reasonable protection against harmful interference in a residential installation. This equipment generates, uses and can radiate radio frequency energy and, if not installed and used in accordance with the instructions, may cause harmful interference to radio communications. However, there is no guarantee that interference will not occur in a particular installation. If this equipment does cause harmful interference to radio or television reception, which can be determined by turning the equipment off and on, the user is encouraged to try to correct the interference by one or more of the following measures:

- Reorient or relocate the receiving antenna.
- Increase the separation between the equipment and receiver.
- Connect the equipment into an outlet on a circuit different from that to which the receiver is connected.
- Consult the dealer or an experienced radio/TV technician for help.

This device contains license-exempt transmitter(s)/receiver(s) that comply with Innovation, Science and Economic Development Canada's license-exempt RSS(s). Operation is subject to the following two conditions:

1. This device may not cause interference.
2. This device must accept any interference, including interference that may cause undesired operation of the device.

The device operates in the band 5150–5250 MHz to reduce the potential for harmful interference to co-channel mobile satellite systems.

For any installation questions, contact us at:

888-653-0160

[evochargesupport@phillipsandtemro.com](mailto:evochargesupport@phillipsandtemro.com)



**[evocharge.com](http://evocharge.com)**

For more resources and  
product documents